



15F590

Wheel & Brake Changer



Building Quality Ground Support Products Since 1961

- Facilitates Wheel and Brake Disc Changes
- One-man operation, reduces man-hour requirement
- Will not interfere with gear jacks
- Eliminates necessity of lifting wheels, tires, or brake disc
- Services the following jet aircraft:
 - Boeing 707, 727, 737, 747, 757, 767, 777, 787
 - Douglas DC-8, DC-9, DC-10
 - Lockheed L-1011
 - Airbus A300/310, A318-A321, A330/340, A350, A380

CLYDE

Clyde Machines
P.O. Box 194
1150 Hwy 55 N.
Glenwood, MN 56334 USA
(320) 634-4504
(320) 634-4506 Fax

www.clydemachines.com

15F590

Wheel & Brake Changer

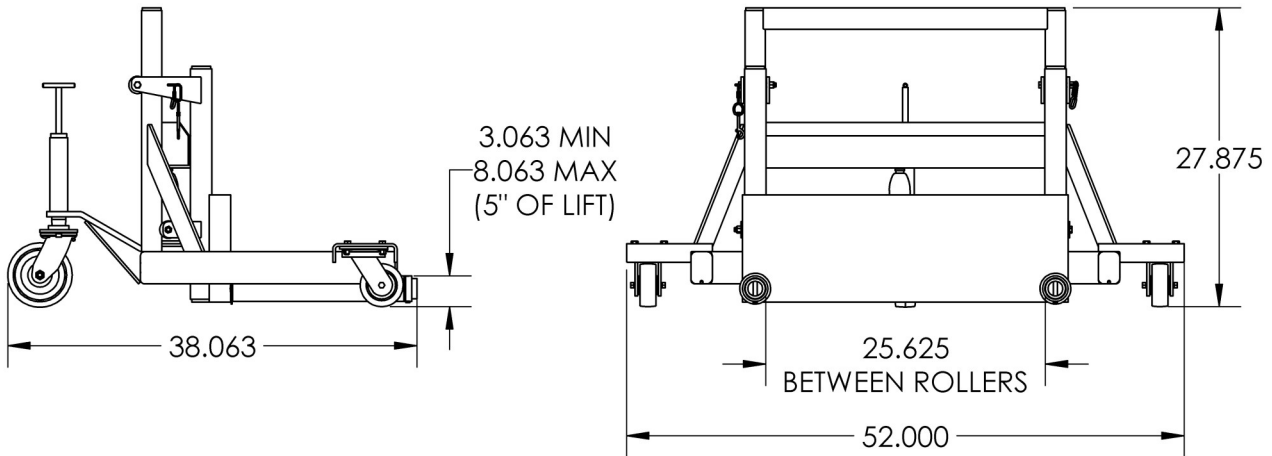

Shipping Dimensions - Crated

- 58" x 39" x 34"
- 440 lbs. (370 lbs. without cradle)

Shipping Dimensions - Pallet

- 54" x 48" x 34"
- 340 lbs. (270 lbs. without cradle)

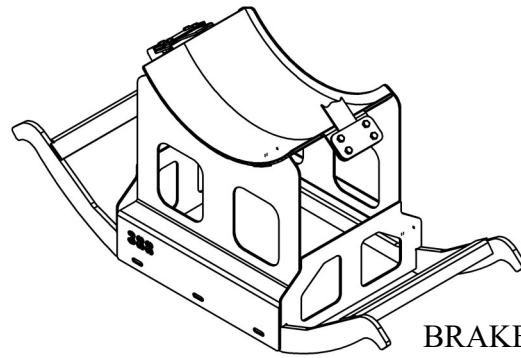

BRAKE CRADLE
* 3 options, see below

- Three Heavy Duty Casters
- Steel Rollers to support wheels, tires, or brake cradle and discs
- Hand operated screw jack to provide fore and aft tilt
- Hand operated hydraulic pump to provide vertical lift
- Durable powder coat finish
- Chain for securing wheel
- Storage box
- Max lift capacity - 750 lbs.
- Brake Cradle Options:
 - 15F389 — Boeing 737, DC-9
 - 15F388 — Boeing 707, 727, 757
Douglas DC-8
Airbus A300/310
Airbus A318-A321
 - 15F679 — Boeing 747, 767, B777, B787
Douglas DC-10
Lockheed L-1011
Airbus A330, A340 (all series)
A350, A380

CLYDE

Clyde Machines
P.O. Box 194
1150 Hwy 55 N.
Glenwood, MN 56334 USA
(320) 634-4504
(320) 634-4506 Fax

www.clydemachines.com