



15F3510

Radome Maintenance Stand



Building Quality Ground Support Products Since 1961

- Designed to safely access crown of all narrow body aircraft
- Contoured hydraulically adjustable cage to match narrow body fuselage
- 750 lb. platform capacity, 2,500 lbs. overall
- Hydraulically elevates 186.5" to 300"
- Double acting hydraulic hand pump with two 2" dia. x 35" stroke lift cylinders, plus an air over hydraulic system
- Hydraulic restrictors in case of pressure failure
- Safety strut with pins
- Non-slip steel grip-strut steps
- Two fall arrest anchor points in upper platform
- Fixed rear and swivel front casters provide ease in maneuverability.
- Hand adjustable screw jacks on each corner for stability
- Drop down pole to tow stand
- 16" diameter solid tires
- Optional:
 - 12 volt work light pkg.
 - Safety mesh on contoured cage
 - Saloon style entry doors in upper platform

CLYDE

Clyde Machines
P.O. Box 194
1150 Hwy 55 N.
Glenwood, MN 56334 USA
(320) 634-4504
(320) 634-4506 Fax

www.clydemachines.com

15F3510

Radome Maintenance Stand

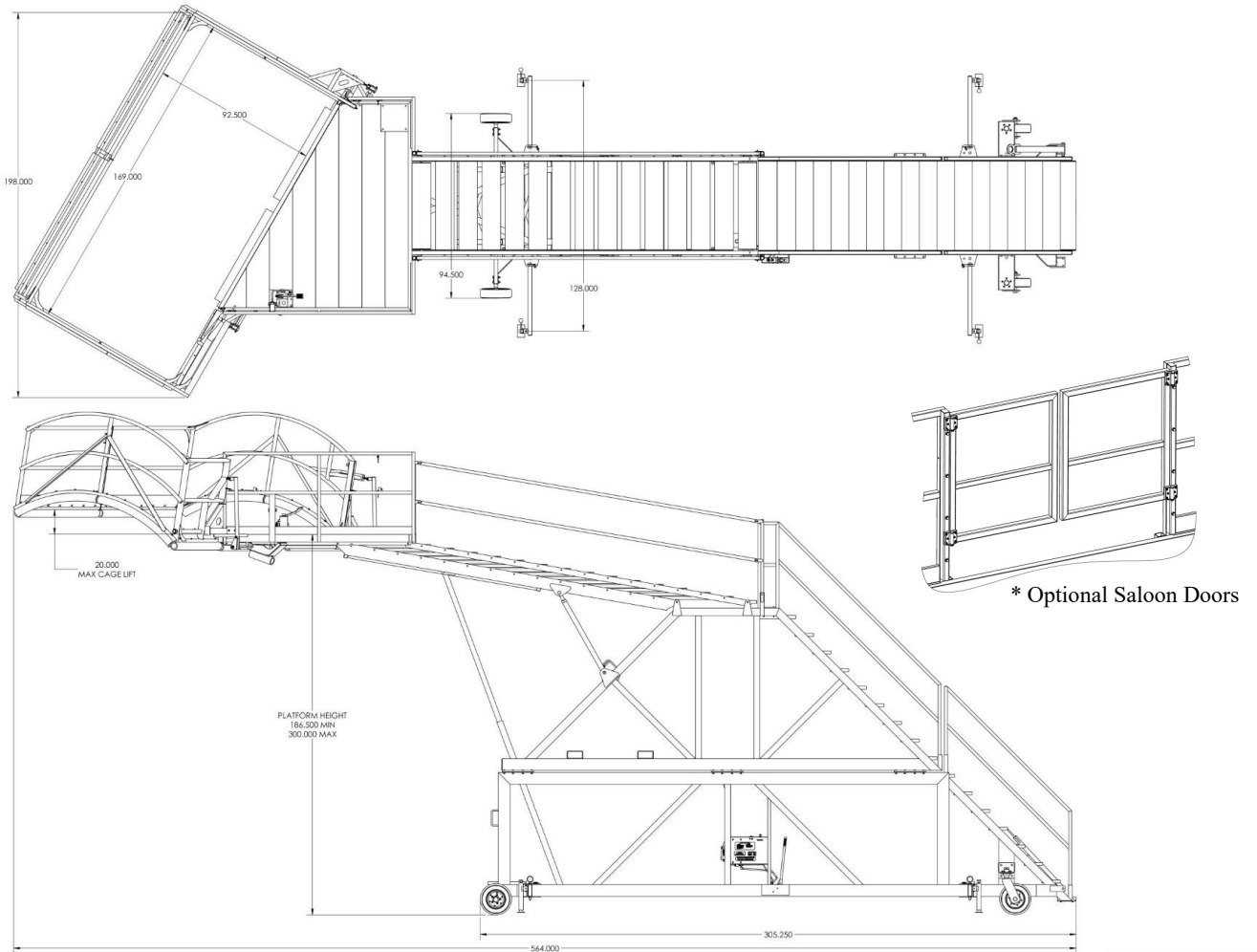

Shipping Information

- Dimensions:
 - Weight - 8,000 lbs.
 - Shipping length - 53'
 - Ships in 3 pieces (53' step deck with required riser or load leveler)

CLYDE

Clyde Machines
P.O. Box 194
1150 Hwy 55 N.
Glenwood, MN 56334 USA
(320) 634-4504
(320) 634-4506 Fax

www.clydemachines.com