



15F2805 & 15F2810

Container Trailer



Building Quality Ground Support Products Since 1961

- Cargo Capacity - 3500 lbs.
- Pallet Capacity - LD1, LD2, and LD3
- Two wheel steering (15F2810), Four wheel steering (15F2805)
- Containers rotate without complicated mechanisms = less maintenance
- Trailers are stackable for easy storage and safe shipping
- Towbar activated parking brake
- Long tie rod protected from impact
- Casters and rollers protected from impact
- Recessed frame to protect customer markings
- 4.00 x 8, 3 stage solid tires on 7 ga. rims
- Max tow speed of 15 mph (24 kph)
- Durable powder coat finish
- Under carriage protection (optional)

CLYDE

Clyde Machines
P.O. Box 194
1150 Hwy 55 N.
Glenwood, MN 56334 USA
(320) 634-4504
(320) 634-4506 Fax

www.clydemachines.com

15F2805 & 15F2810

Container Trailer

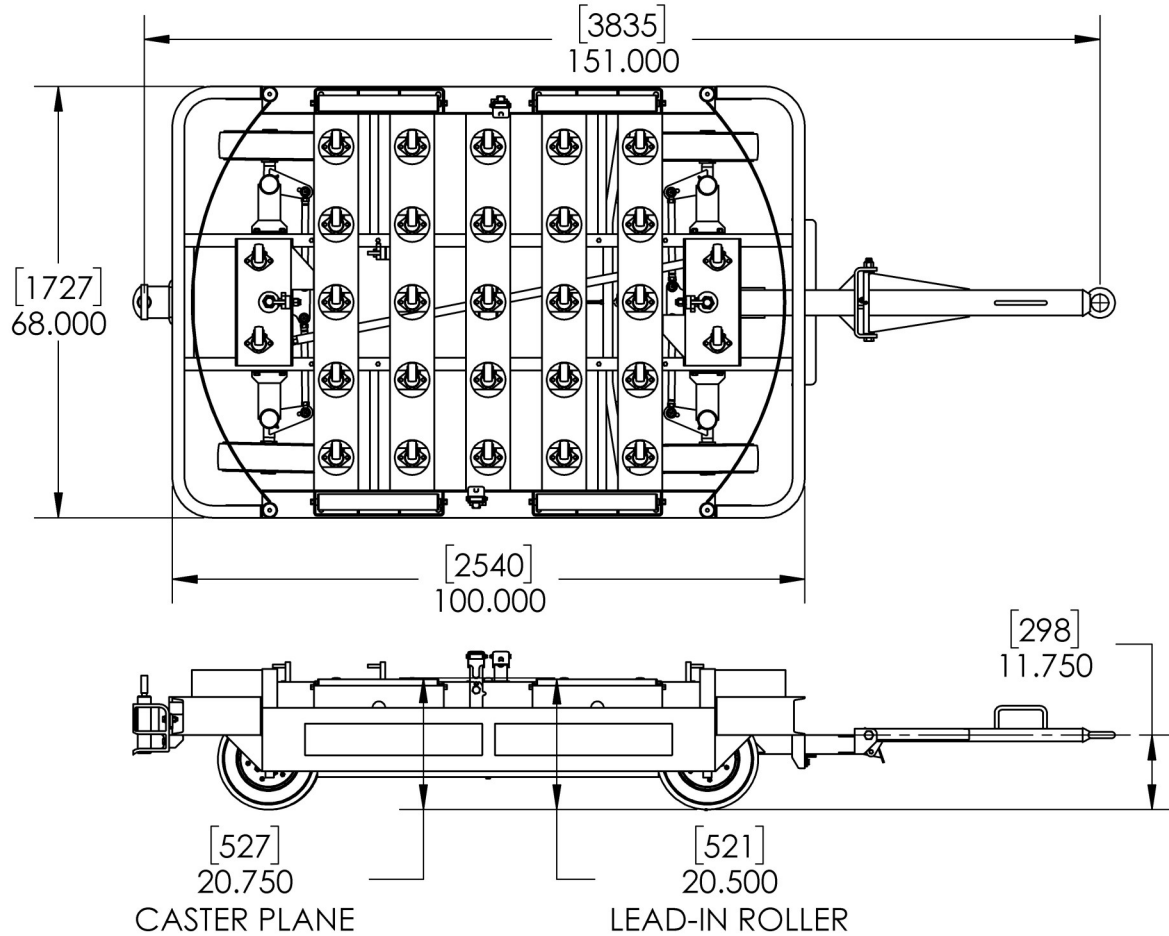

Shipping Information

- Dimensions:
 - Weight - 1200 lbs.
 - Length (towbar up) - 134"
 - Length (towbar down) - 156"
 - Width - 68"
 - Height - 24"

CLYDE

Clyde Machines
P.O. Box 194
1150 Hwy 55 N.
Glenwood, MN 56334 USA
(320) 634-4504
(320) 634-4506 Fax

www.clydemachines.com