



15F3300

Wide Body Towbar



Building Quality Ground Support Products Since 1961

- Fully retractable hydraulic running gear for adjustable height
 - Safety lock system to avoid separation from aircraft
 - Tube made of high strength steel
 - Quality shear bolts for aircraft protection
 - Durable powder coat finish
 - Extra set of shear pins included
 - Pneumatic tires
- Model Fits:
- DC10
 - B767
 - L1011
 - A 340 200/300
 - MD 11
 - A330
 - A350
 - B777*
 - B787**
 - IL-96
 - C17

CLYDE

Clyde Machines
P.O. Box 194
1150 Hwy 55 N.
Glenwood, MN 56334 USA
(320) 634-4504
(320) 634-4506 Fax

www.clydemachines.com

15F3300

Wide Body Towbar

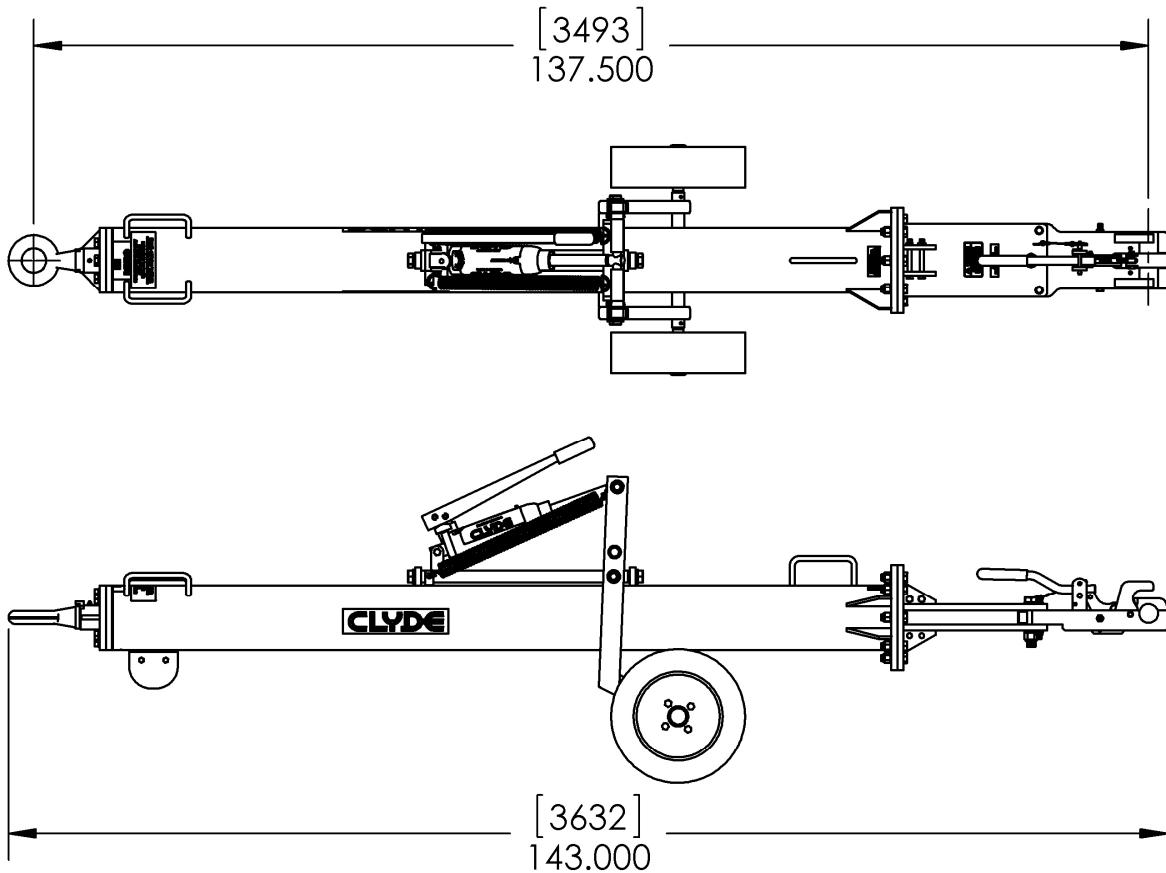

Shipping Information

Shipping weight:

- 650 lbs.

Shipping Dimensions:

- Length — 144"
- Width — 29"
- Height — 25"

Crated shipping weight:

- 930 lbs.

Crated dimensions:

- Length — 152"
- Width — 22"
- Height — 30"

* "For use as dedicated B777/B787 towbar a shear pin, part #1504708, is offered. This heavier shear pin is not for use on other applicable aircraft models."

** "Some pushback tractors may require a longer towbar to clear aircraft nose. Model 15F3045 is offered"

CLYDE

Clyde Machines

P.O. Box 194
1150 Hwy 55 N.
Glenwood, MN 56334 USA
(320) 634-4504
(320) 634-4506 Fax

www.clydemachines.com